

Throttle and Shut-Off Valve - Type DV (In-Line Assembly)

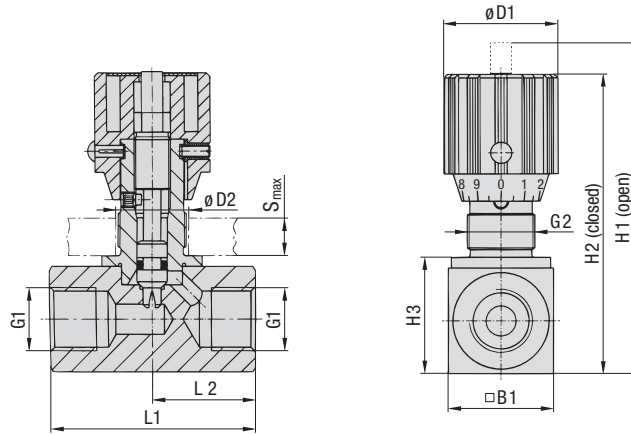

Characteristics

Throttle and shut-off the flow of liquid media in both directions

Features

- Designed for in-line assembly with female BSP, NPT and SAE threaded connections
- Panel mounting nuts available on request
- Graduated turning knob and coded spindle to accurately control flow
- Set-screw located on side of turning knob to lock valve in position

Media Compatibility

- Suitable for hydraulic fluids

Please contact STAUFF before using with other media.

Materials

- Body and spindle made of Steel (1.0715), zinc/iron-plated (Fe/Zn Fe Co 8 C) and free of hexavalent chromium CrVI (standard option); Stainless Steel (1.4571) version available
- Turning knob made of Polyamide (PA)
- O-rings made of NBR (Buna-N®); FKM/FPM (Viton®) and EPDM sealed version available

Contact STAUFF for alternative materials.

Technical Data

- Maximum working pressure: 350 bar / 5000 PSI (for all sizes)
- Operating temperature range: -20°C ... +100°C / -4°F ... +212°F

Please see page 100 for detailed flow characteristics.

Dimensions

Type + Nominal Size	Thread Options G1	Dimensions (mm/in)										Weight (kg/lbs)
		G2	H1	H2	H3	B1	ØD1	ØD2	S (Max.)	L1	L2	
DV-06	G1/8 BSP 1/8 NPT	PG 7	64	59	18	16	24	13	3	38	19	0,12
			2.52	2.32	.71	.63	.94	.51	.12	1.50	.75	.26
DV-08	G1/4 BSP 1/4 NPT 7/16-20 UNF (1/4" SAE)	PG 11	83,5	77,5	27	25	29	19	7	48	24	0,25
			3.29	3.05	1.06	.98	1.14	.75	.28	1.89	.94	.55
DV-10	G3/8 BSP 3/8 NPT 9/16-18 UNF (3/4" SAE)	PG 11	90	83	32	30	29	19	7	58	29	0,40
			3.54	3.27	1.26	1.18	1.14	.75	.28	2.28	1.14	.88
DV-12	G1/2 BSP 1/2 NPT 3/4-16 UNF (1/2" SAE)	PG 11	109,5	99,5	38	35	38	23	7	68	34	0,60
			4.31	3.92	1.50	1.38	1.50	.91	.28	2.68	1.34	1.32
DV-16	G3/4 BSP 3/4 NPT 1-1/16-12 UN (3/4" SAE)	PG 16	128,5	118,5	48	45	38	23	7	78	39	1,10
			5.06	4.67	1.89	1.77	1.50	.91	.28	3.07	1.54	2.43
DV-20	G1 BSP 1 NPT 1-5/16-12 UN (1" SAE)	PG 16	159	146	55	50	49	38	10	108	54	2,40
			6.26	5.75	2.17	1.97	1.93	1.50	.39	4.25	2.13	5.29
DV-25	G1-1/4 BSP 1-1/4 NPT 1-5/8-12 UN (1-1/4" SAE)	PG 29	169	156	65	60	49	38	10	108	54	2,80
			6.65	6.14	2.56	2.36	1.93	1.50	.39	4.25	2.13	6.17
DV-30	G1-1/2 BSP 1-1/2 NPT 1-7/8-12 UN (1-1/2" SAE)	PG 29	175	166	75	70	49	38	10	108	54	3,50
			6.89	6.54	2.95	2.76	1.93	1.50	.39	4.25	2.13	7.72
DV-40	G2 BSP 2 NPT 2-1/2-12 UN (2" SAE)	PG 29	199	186	95	90	49	38	10	120	60	6,30
			7.83	7.32	3.74	3.54	1.93	1.50	.39	4.72	2.36	13.89

Order Codes

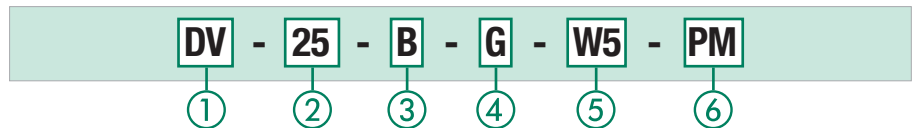

① Type

Throttle and Shut-Off Valve (In-Line Assembly) **DV**

② Nominal Size DN

06 08 10 12 16 20 25 30 40

③ Sealing Material

NBR (Buna-N®) (standard option) **B**
FKM/FPM (Viton®) **V**
EPDM **E**

④ Connection

Female BSP threads (ISO 228) **G**
Female NPT threads (ANSI B1.20.1) **N**
Female UN/UNF thread (SAE J514) **U**

⑤ Body / Spindle Material

Steel, zinc/iron-plated (standard option) **—**
Stainless Steel **W5**

⑥ Panel Mounting Nut

Without panel mounting nut (standard option) **—**
With panel mounting nut **PM**

