

KHB3K (BK3) 系列二位三通球阀

KHB3K(BK3) Two-position Three-way High Pressure Ball Valve

型号说明 Model Code

KHB3K-G1/2-13-LN-1111-01-1
 1 2 3 4 5 6 7 8 9 10 11

1. 系列代号: KHB3K (BK3) 系列二位三通球阀;
2. 连接代号: G**, M**, **LR, **SR, PT**, NPT**;
3. 公称通径: 04, 06, 08, 10, 13, 16, 20, 25, 32, 40, 50, ;
4. 球芯机能: L-L型机能球芯、T-T型机能球芯;
5. 阀体工作油口 (三通球阀与直通球阀区别的油口) 连接螺纹: N-内螺纹、W-外螺纹;
6. 阀体、接头材料: 1-45#, 3-316不锈钢;
7. 球芯、阀锁材料: 1-45#, 3-316不锈钢;
8. 球封材料: 1-POM (聚甲醛)、2-PTFE(聚四氟乙烯);
9. 阀体与接头和阀锁处密封材料: 1-NBR(丁晴橡胶)、2-FPM/FKM(氟橡胶);
10. 手柄形式: 01-C型锌合金曲手柄、02-B型锌合金曲手柄、03-B型钢制曲手柄、09-不带手柄;
11. 表面处理: 1-蓝白三价铬;

备注: 压力参数对应产品的材料为碳钢。

材料1111为常规组合, PTFE材料使用时最高工作压力不超过100bar
 (其它特殊组合型式请咨询)。

1. Series Code: KHB3K Two-position Three-way High Pressure Ball Valve
 2. Joint Code: G**, M**, **LR, **SR, PT**, NPT**;
 3. Nominal Diameter: 04, 06, 08, 10, 13, 16, 20, 25, 32, 40, 50, ;
 4. Ball Valve Enginery: L-L Type, T-T Type
 5. working oil port (difference between three way to straight way) Join Thread: N-female / W-male thread.
 6. Valve body/joint material: 1-carbon steel, 3-316 stainless steel
 7. Ball body/ Valve lock material: 1-carbon steel, 3-316 stainless steel
 8. Ball Sealing material: 1-POM 2-PTFE
 9. Sealing material (linking valve body/joint/valve lock): 1-NBR 2-FPM/FKM
 10. Handle Type: 01-C type zinc alloy crooked handle 02-B type zinc alloy crooked handle 03-B type casting steel crooked handle 09-without handle
 11. Surface Treatment: 1-SILVER ZINC PLATED
- PS: The Material Pressure parameters corresponding to the product is carbon steel.
 1111 is the normal mix, the PN no more than 100bar when using PTFE.
 (other specifications please contact us)

图形符号 Symbol

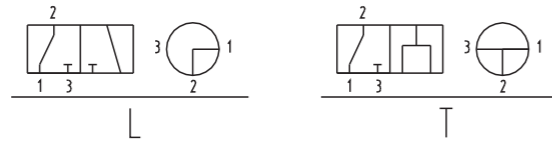

外形尺寸 Overall Dimension

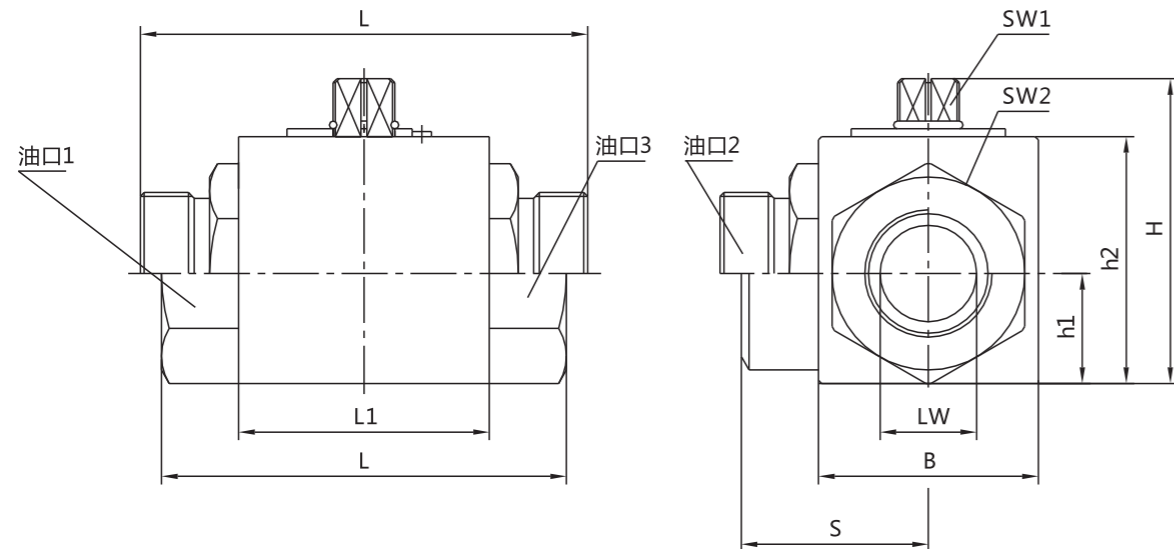

连接口略图 Connection port sketch	简略型号 Brief Model	PN (bar)	DN	LW	RA	d1	i	L	L1	B	H	h1	h2	SW1	SW2	S	
M	KHB3K-M16×1.5	500	06	06	11	M16×1.5	11	69	40	26	45	13.5	33	09	22	27.5	
	KHB3K-M22×1.5	500	08	08	16	M22×1.5	12	76	42	32	49	16	36	09	27	33	
	KHB3K-M27×1.5	500	10	10	20	M27×1.5	12	76	42	32	49	16	36	09	27	33	
	KHB3K-M30×1.5	400	16	15	24	M30×1.5	13	84	48	38	61	19	45	09	32	37	
	KHB3K-M36×2	400	20	20	30	M36×2	15	103	60	48	70	25	55	12	41	45.5	
	KHB3K-M42×2	350	25	25	35	M42×2	18	116	65	57	79	28.5	64	12	50	54	
	KHB3K-M52×2	350	32	30	40	M52×2	20	149	84	75	101	37.5	84	14	60	62.5	
	KHB3K-M60×2	350	40	38	45	M60×2	22	174	91	85	112	42.5	95	14	70	84	
	G	KHB3K-G 1/8	500	04	06		G 1/8	14	69	40	26	45	13.5	33	09	22	34.5
		KHB3K-G 1/4	500	06	06		G 1/4	14	69	40	26	45	13.5	33	09	22	34.5
KHB3K-G 3/8		500	10	10		G 3/8	14	72	42	32	49	16	36	09	27	36	
KHB3K-G 1/2		500	13	12		G 1/2	14	83	47	35	49	18	38	09	30	34	
KHB3K-G 1/2		400	16	15		G 1/2	16	83	48	38	61	19	45	09	32	42	
KHB3K-G 3/4		400	20	20		G 3/4	18	95	60	48	70	25	55	12	41	49	
KHB3K-G 1		350	25	25		G 1	21	113	65	57	79	28.5	64	12	50	56.5	
KHB3K-G 1 1/4		350	32	30		G 1 1/4	22	110	84	75	101	37.5	84	14	60	62.5	
KHB3K-G 1 1/2		350	40	38		G 1 1/2	24	130	91	85	112	42.5	95	14	70	61	
KHB3K-G 2		350	50	48		G 2	26	140	100	104	131	52	112.5	14	90	66	
NPT(PT)	KHB3K-NPT 1/8	500	04	06		NPT 1/8	11	69	40	26	45	13.5	33	09	22	34.5	
	KHB3K-NPT 1/4	500	06	06		NPT 1/4	11	69	40	26	45	13.5	33	09	22	34.5	
	KHB3K-NPT 3/8	500	10	10		NPT 3/8	11	72	42	32	49	16	36	09	27	36	
	KHB3K-NPT 1/2	500	13	12		NPT 1/2	14	83	47	35	49	18	38	09	30	34	
	KHB3K-NPT 1/2	400	16	15		NPT 1/2	14	83	48	38	61	19	45	09	32	42	
	KHB3K-NPT 3/4	400	20	20		NPT 3/4	15	95	60	48	70	25	55	12	41	49	
	KHB3K-NPT 1	350	25	25		NPT 1	17	113	65	57	79	28.5	64	12	50	56.5	
	KHB3K-NPT 1 1/4	350	32	30		NPT 1 1/4	18	110	84	75	101	37.5	84	14	60	66	
	KHB3K-NPT 1 1/2	350	40	38		NPT 1 1/2	18	130	91	85	112	42.5	95	14	70	61	
	KHB3K-NPT 2	350	50	48		NPT 2	18	140	100	104	131	52	112.5	14	90	62.5	
LR	KHB3K-06LR	500	04	04	06	M12×1.5	10	67	40	26	45	13.5	33	09	22	33.5	
	KHB3K-08LR	500	06	06	08	M14×1.5	10	67	40	26	45	13.5	33	09	22	33.5	
	KHB3K-10LR	500	06	08	10	M16×1.5	11	74	40	26	45	13.5	33	09	22	36	
	KHB3K-12LR	500	10	10	12	M18×1.5	11	74	42	32	49	16	36	09	27	36	
	KHB3K-15LR	500	13	12	15	M22×1.5	12.5	82	47	35	53	18	38	09	30	40	
	KHB3K-15LR	400	16	12	15	M22×1.5	12	82	48	38	61	19	45	09	32	40	
	KHB3K-18LR	500	13	12	18	M26×1.5	12.5	82	47	35	53	18	38	09	30	42	
	KHB3K-18LR	400	16	15	18	M26×1.5	12	82	48	38	61	19	45	09	32	42	
	KHB3K-22LR	400	20	19	22	M30×2	14	101	60	48	70	25	55	12	41	49	
	KHB3K-28LR	350	25	25	28	M36×2	14	108	65	57	79	28.5	64	12	50	54	
SR	KHB3K-08SR	500	04	05	08	M16×1.5	12	73	40	26	45	13.5	33	09	22	34.5	
	KHB3K-10SR	500	06	06	10	M18×1.5	12	73	40	26	45	13.5	33	09	22	34.5	
	KHB3K-12SR	500	08	08	12	M20×1.5	12	76	40	26	45	13.5	33	09	22	36	
	KHB3K-14SR	500	10	10	14	M22×1.5	14	80	42	32	49	16	36	09	27	36	
	KHB3K-16SR	500	13	12	16	M24×1.5	14	86	47	35	53	18	38	09	30	44	
	KHB3K-16SR	400	16	13	16	M24×1.5	14	86	48	38	61	19	45	09	32	37	
	KHB3K-20SR	500	13	12	20	M30×2	16	90	47	35	53	18	38	09	30	44	
	KHB3K-20SR	400	16	15	20	M30×2	16	90	48	38	61	19	45	09	32	37	
	KHB3K-25SR	400	20	20	25	M36×2	18	109	60	48	70	25	55	12	41	49	
	KHB3K-30SR	350	25	25	30	M42×2	20	120	65	57	79	28.5	64	12	50	60	
KHB3K-38SR	350	32	30	38	M52×2	22	153	84	75	101	37.5	84	14	60	76.5		