

D4SL-N / D4SL-NSK10-LK□

Model	Contact (door open/closed detection and lock monitor)	Contact Form		Operating pattern	Remarks
		Lock monitor	Door open/closed detection		
D4SL-N□E□□-□	2NC/1NO+1NC/1NO				Only NC contact 11-12 and 21-22 has a certified direct opening mechanism. ⊖ The terminals 42-11, 22-21, 34-33, and 64-63 can be used as unlike poles.
D4SL-N□F□□-□	2NC/1NO+2NC				Only NC contact 11-12 and 21-22 has a certified direct opening mechanism. ⊖ The terminals 42-11, 22-21, 34-33, and 62-61 can be used as unlike poles.
D4SL-N□G□□-□	3NC+1NC/1NO				Only NC contact 11-12, 21-22 and 31-32 has a certified direct opening mechanism. ⊖ The terminals 42-11, 22-21, 32-31, and 64-63 can be used as unlike poles.
D4SL-N□H□□-□	3NC+2NC				Only NC contact 11-12, 21-22 and 31-32 has a certified direct opening mechanism. ⊖ The terminals 42-11, 22-21, 32-31, and 62-61 can be used as unlike poles.
D4SL-N□N□□-□	2NC/1NO+2NC/1NO				Only NC contact 11-12 and 21-22 has a certified direct opening mechanism. ⊖ The terminals 42-11, 52-21, 34-33, and 64-63 can be used as unlike poles.
D4SL-N□P□□-□	2NC/1NO+3NC				Only NC contact 11-12 and 21-22 has a certified direct opening mechanism. ⊖ The terminals 42-11, 52-21, 34-33, and 62-61 can be used as unlike poles.
D4SL-N□Q□□-□	3NC+2NC/1NO				Only NC contact 11-12, 21-22 and 31-32 has a certified direct opening mechanism. ⊖ The terminals 42-11, 52-21, 32-31, and 64-63 can be used as unlike poles.
D4SL-N□R□□-□	3NC+3NC				Only NC contact 11-12, 21-22 and 31-32 has a certified direct opening mechanism. ⊖ The terminals 42-11, 52-21, 32-31, and 62-61 can be used as unlike poles.

Dimensions and Operating Characteristics

(Unit:mm)

Switches

D4SL-N□□□□-□N (Connector Type)

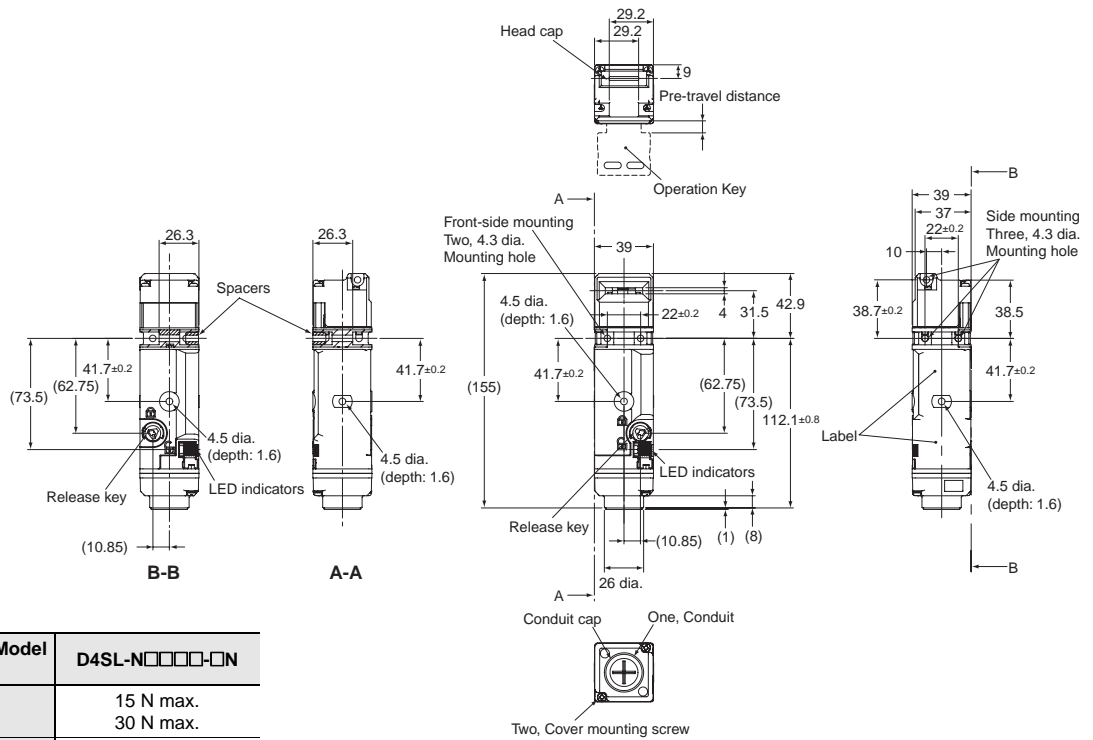

Model	D4SL-N□□□□-□N
Operating characteristics	
Key insertion force	15 N max.
Key extraction force	30 N max.
Pre-travel distance	15 mm max.
Movement before being locked	3 mm min.

D4SL-N□□□□-□ (Terminal Block Type)

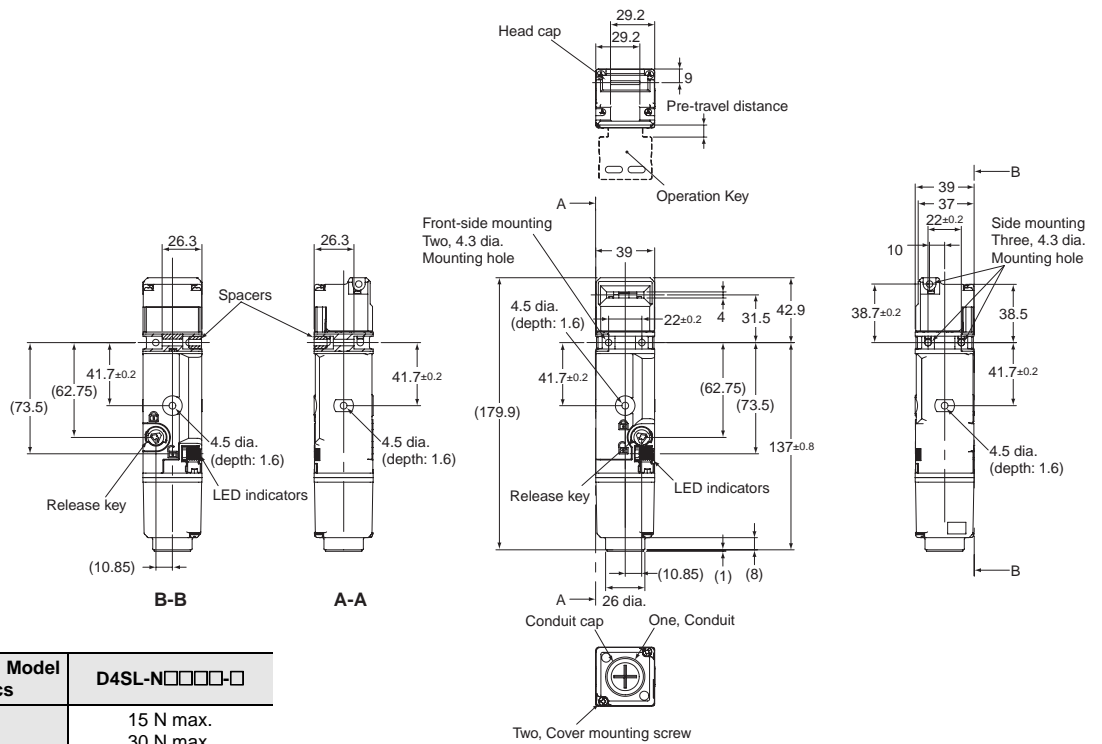

Model	D4SL-N□□□□-□
Operating characteristics	
Key insertion force	15 N max.
Key extraction force	30 N max.
Pre-travel distance	15 mm max.
Movement before being locked	3 mm min.

Note: Unless otherwise specified, a tolerance of ±0.4 mm applies to all dimensions.

D4SL-N / D4SL-NSK10-LK□

Operation key

D4SL-NK1

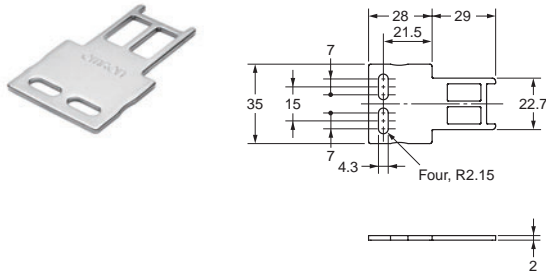

D4SL-NK1S

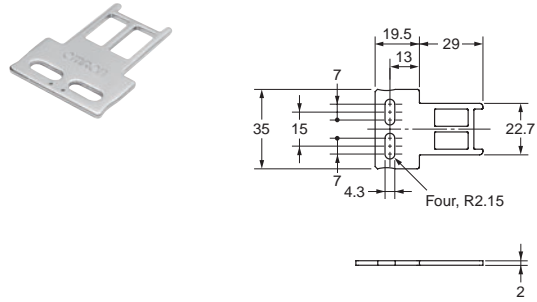

D4SL-NK1G

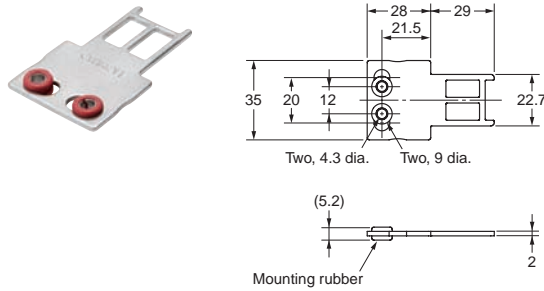

D4SL-NK2

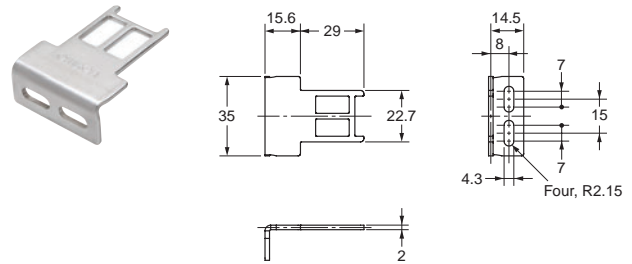

D4SL-NK2G

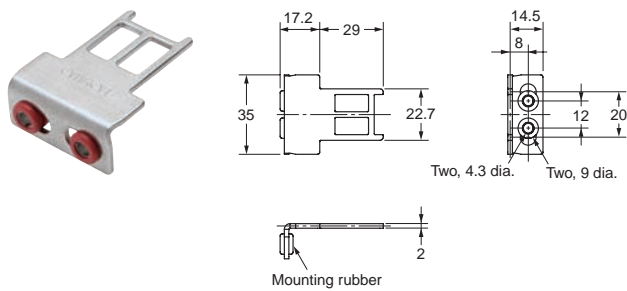

D4SL-NK3

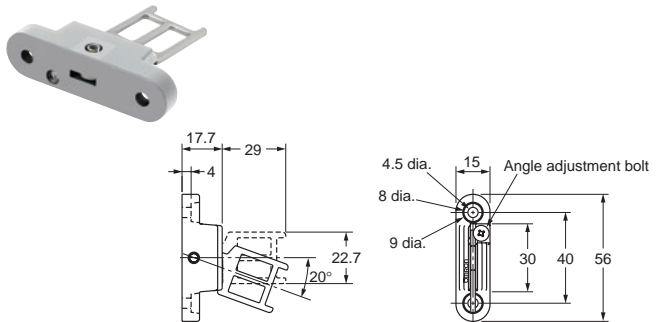

Note: Unless otherwise specified, a tolerance of ± 0.4 mm applies to all dimensions.

Connector Cables

D4SL-CN□

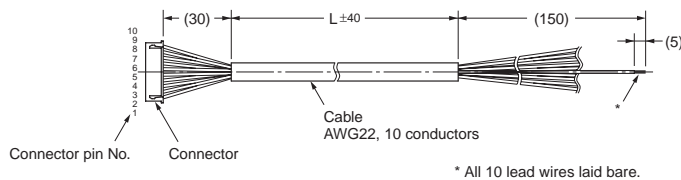

Model	L size
D4SL-CN1	1 m
D4SL-CN3	3 m
D4SL-CN5	5 m

Connector No.	Lead wire color	Connector No.	Lead wire color
1	Black	6	Green/White
2	Black/White	7	Yellow
3	Red	8	Yellow/White
4	Red/White	9	Brown
5	Green	10	Brown/White

Slide Key

D4SL-NSK10-LK

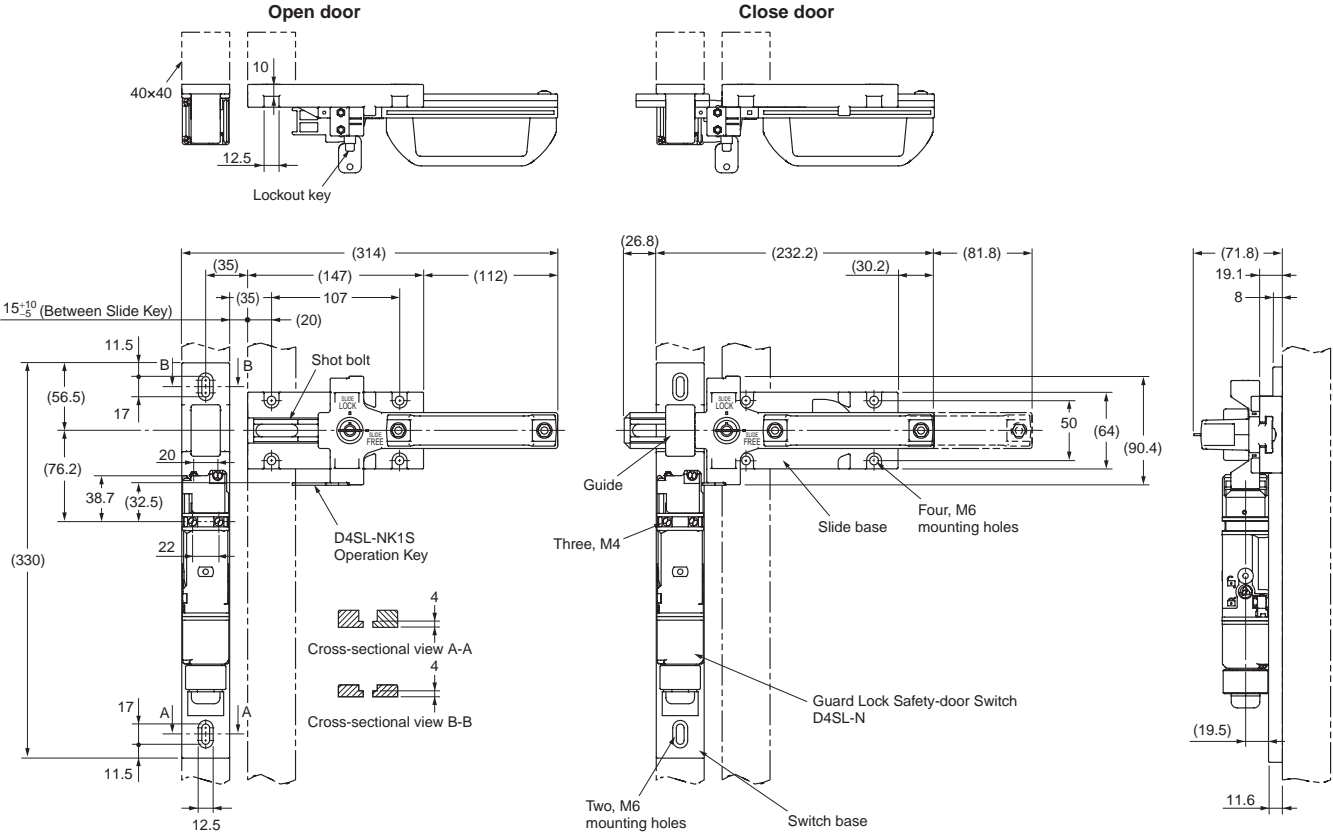

D4SL-NSK10-LKH

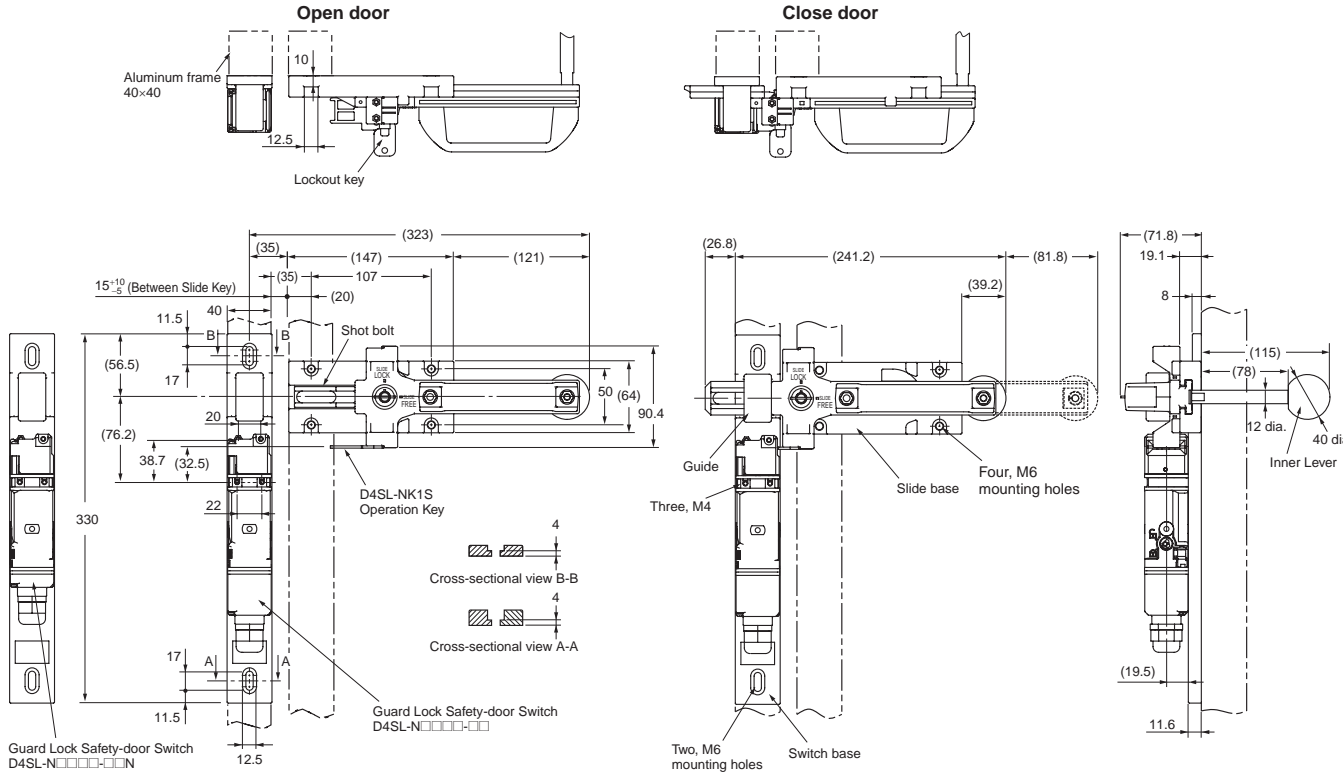

Operation key Mounting

D4SL-N+D4SL-NK1



With Front-inserted Operation Key

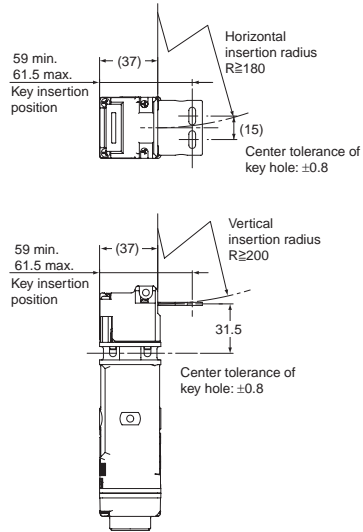

With Top-inserted Operation Key

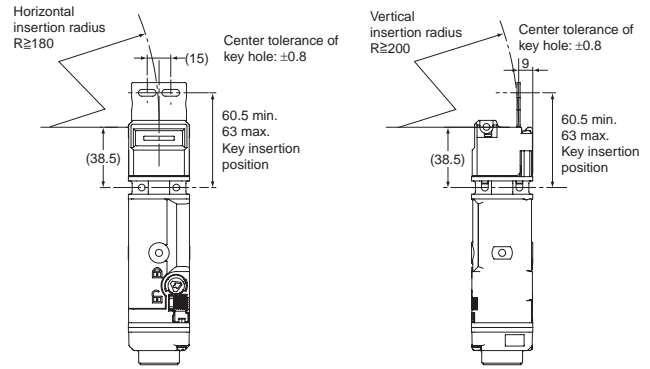

D4SL-N+D4SL-NK1S



With Front-inserted Operation Key

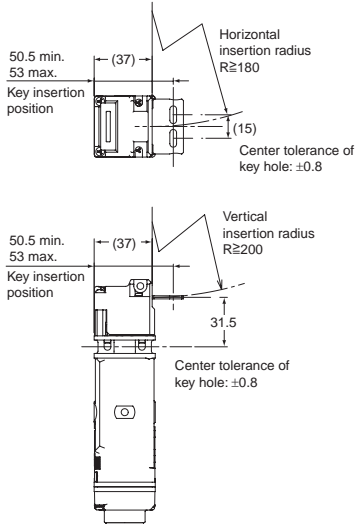

With Top-inserted Operation Key

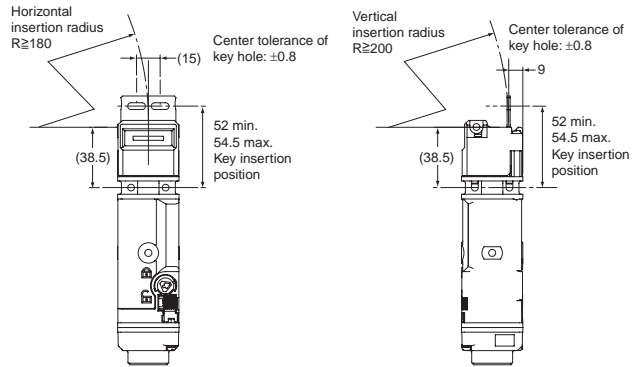

D4SL-N+D4SL-NK1G



With Front-inserted Operation Key

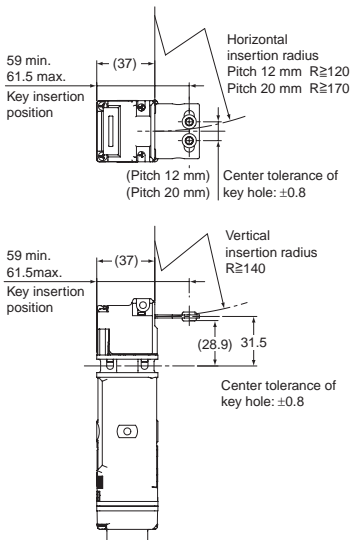

With Top-inserted Operation Key

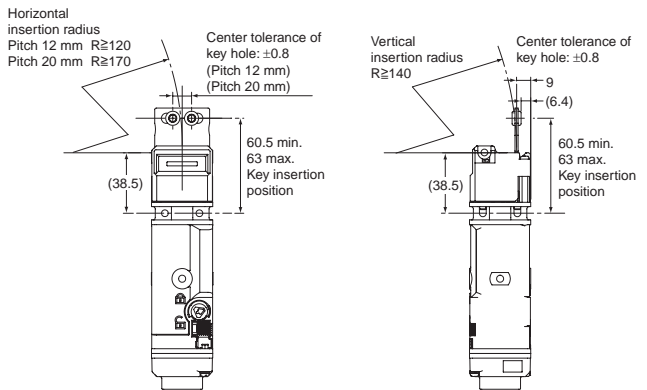

D4SL-N+D4SL-NK2



With Front-inserted Operation Key

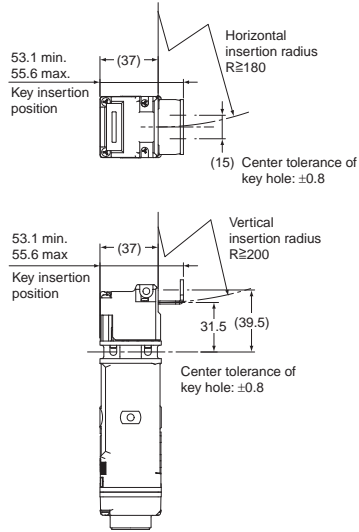

With Top-inserted Operation Key

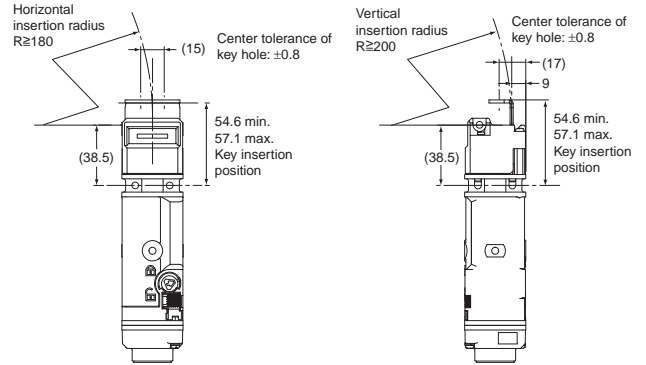

D4SL-N+D4SL-NK2G



With Front-inserted Operation Key

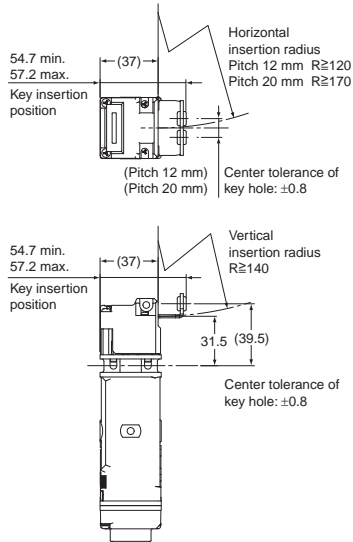

With Top-inserted Operation Key

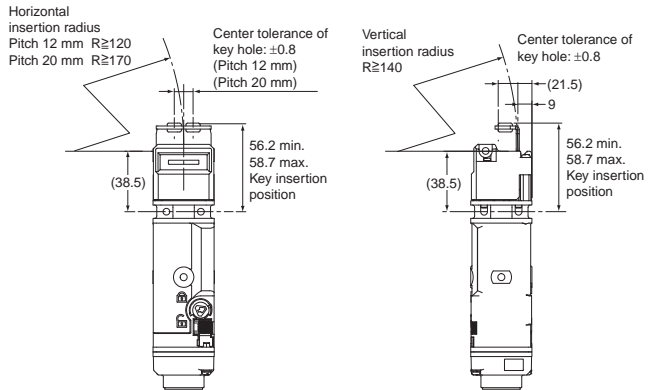

D4SL-N+D4SL-NK3



With Front-inserted Operation Key

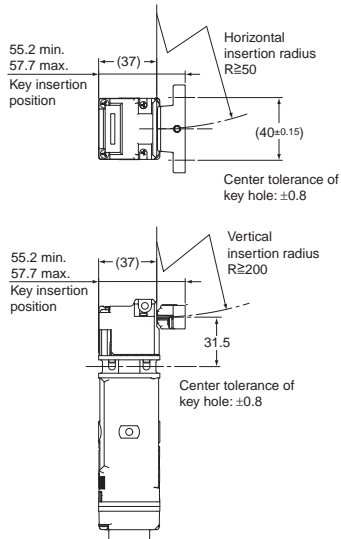

With Top-inserted Operation Key

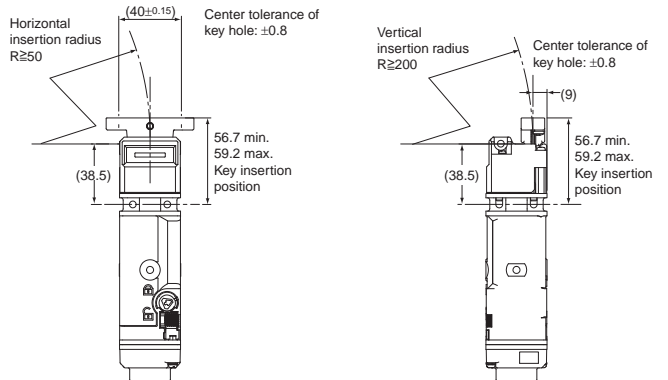

D4SL-N / D4SL-NSK10-LK□

Application Example

D4SL-N Application Example

PL/Safety Category	Applied models	Stop category	Reset method
Equivalent to PLe/4	D4SL-N□R□A□ Compact Safety Door Switch with Magnetic Lock (mechanical lock) G9SA-301 (24 VAC/DC) Safety Relay Unit	0	Manual

Application Overview

- If the guard is opened, it is detected with S2 and the power supply to the motor (M) is shut OFF.
- When the guard is closed, the lock status can be detected and the power supply to the motor (M) remains shut OFF until limit switch S3 is pressed.

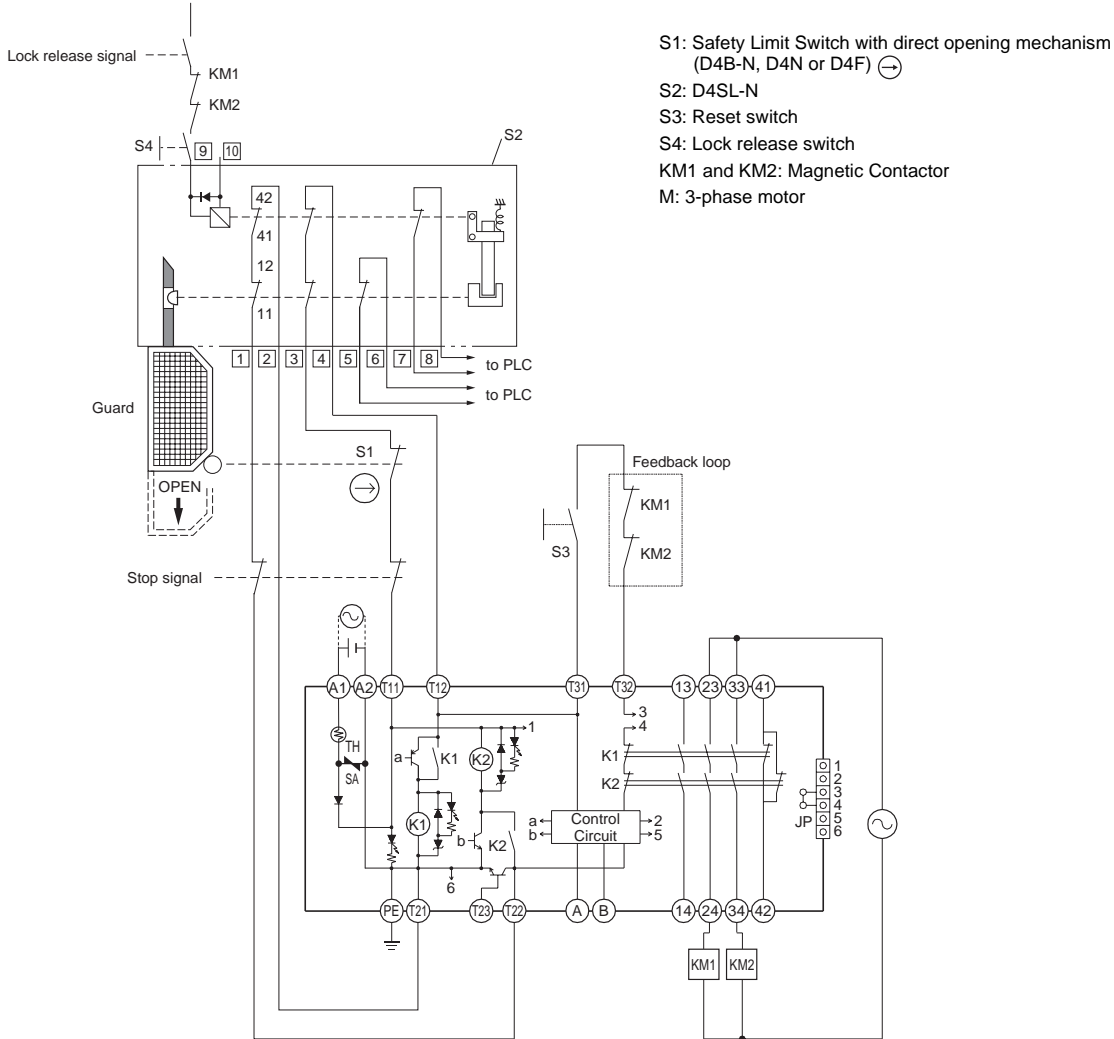

Timing Chart

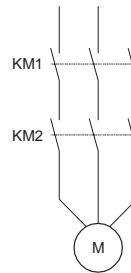
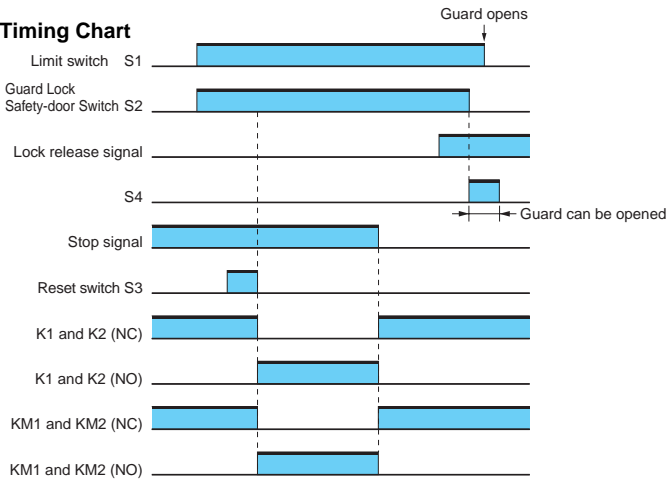

- Note:**
1. The above circuit diagram is for Category 3.
 2. Numbers inside the boxes are terminal numbers printed on the product.

Safety Precautions

Be sure to read the precautions for All Safety Door Switches in the website at:<http://www.ia.omron.com/>.

⚠ DANGER	Indicates an imminently hazardous situation which, if not avoided, is likely to result in serious injury or may result in death. Additionally there may be severe property damage.
⚠ CAUTION	Indicates a potentially hazardous situation which, if not avoided, may result in minor or moderate injury or in property damage.
Precautions for Safe Use	Supplementary comments on what to do or avoid doing, to use the product safely.
Precautions for Correct Use	Supplementary comments on what to do or avoid doing, to prevent failure to operate, malfunction or undesirable effect on product performance.

⚠ DANGER

Injury may occasionally occur. Always check to make sure that the safety functions operate correctly before using the machine. The safety functions may not operate correctly because of wiring mistakes, setting mistakes, or Switch malfunction, causing some machines to continue operating in situations where they should be stopped.



⚠ CAUTION

D4SL-N

Injury may occasionally occur. When the Switch function is damaged, some machines may continue operating in situations where they should be stopped. Do not impose a force exceeding the key holding force. Always provide a lock separate from the Switch, attach a warning seal to avoid excessive force applied to the Switch, or provide an indicator lamp to show the locked/unlocked status of the door.



D4SL-NSK10-LK□

Do not use this product mounted so that it slides vertically. This may cause malfunction, resulting in personal injury.



Do not insert the operation key with the door open. Devices may start to operate, resulting in injury.



Precautions for Safe Use

D4SL-N

Operating Environment

Do not use the Switch submersed in oil or water or in locations continuously subject to splashes of oil or water. Doing so may result in oil or water entering the Switch. (The IP67 degree of protection of the Switch specifies the amount of water penetration after the Switch is submersed in water for a certain period of time.)

Wiring

- Do not switch circuits for three or more standard loads (125 VAC, 1A). Doing so may adversely affect insulation performance.
- Do not allow the load current to exceed the rated value. For metal connector, use a connector with the screw length of 9 mm or less. Otherwise it may result in electric shock.
- Do not use metallic conduits. In the event of damage to the conduit opening, this may cause seal failure and may result in electric shock.
- Do not use a metal connector for a 1/2-14NPT connector. In the event of damage to the conversion adapter, this may cause seal failure and may result in electric shock.
- Always attach the cover after completing wiring and before using the Switch. Do not supply power when the cover is not attached. Electric shock may occur if the Switch is used without the cover attached.
- When using the terminal block type, make sure that foreign material does not adhere to the terminal block board. Otherwise a short circuit may occur between terminals and safety functions may fail to work properly.

Installation

- Make sure the Switch is mounted securely to prevent it from falling off. Otherwise injury may result.
- Do not use a Switch as a stopper. Be sure to install a stopper as shown in the following illustration so that the Operation Key does not touch the head. Do not subject the Switch to a shock that exceeds the Switch's shock resistance of 1,000 m/s².

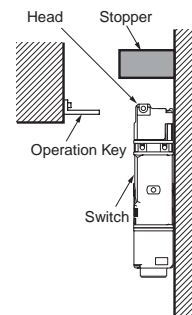

D4SL-NSK10-LK□

- Do not drop the Product. Doing so may prevent the Product from functioning to full capacity.
- Mount the Product securely to prevent it from falling. Otherwise, injury may occur.
- Do not attempt to disassemble or modify the Switch. Doing so may cause the Switch to malfunction.
- Make sure that the gap between the shot bolt and the guide is ± 0.5 mm. Otherwise, excessive wear or damage may cause malfunction.
- To ensure safety, do not operate the Switch with anything other than the Slide Key Unit.
- Your hand may be injured by being pinched between the Operation Key and Switch when closing the door with your hand on the Product.
- Be careful to avoid pinching your hand when operating the Slide Handle.
- Do not impose a force of exceeding 1 N•m when operating the Lockout Key. Otherwise, the Product may be damaged and may not operate properly. To prevent damage, attach the supplied labels for display near the Product.
- Do not force the slide handle to move when the lockout key is not inserted. Doing so may damage the product and make operation impossible.
- Do not force the slide handle to move when the door is locked. Doing so may damage the product and make operation impossible.
- Do not close the door with the shot bolt removed. Doing so may damage the product and make operation impossible.
- Turn the Lockout Key to the "SLIDE LOCK" position and remove it when opening the door to prevent a third party from operating the Slide Handle.
- The durability of the Switch varies considerably depending on the switching conditions. Always confirm the usage conditions by using the Switch in an actual application, and use the Switch only for the number of switching operations given in the performance specifications.
- The user must not maintain or repair equipment incorporating the Switch. Contact the manufacturer of the equipment for any maintenance or repairs required.
- Refer to the *D4SL-N Guard Lock Safety-door Switch Instruction Sheet* about storage conditions, ambient conditions, Switch details, and handling methods.
- Do not apply excessive force in the direction of the slide. This may damage the product and cause it to malfunction.
- Do not force the switch or cable. This may damage the product. The cable should be fixed at a point separate from the switch.

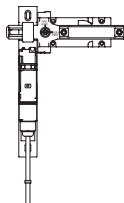

Precautions for Correct Use

D4SL-N

Solenoid Lock Models

- Be sure to supply power to the solenoid after the door is closed (after the Operation Key is inserted).
- The solenoid lock locks the door only when power is supplied to the solenoid. Therefore, the door will be unlocked if the power supply to the solenoid stops. Therefore, do not use solenoid lock models for machines that may be operating and dangerous even after the machine stops operating.

Release Key

- The release key is used to unlock the Switch in case of emergency or if the power supply to the Switch stops.
- If the release key setting is changed from LOCK to UNLOCK, the lock will be released and the safety door can be opened (mechanical lock models only).

Front

D4SL-N□□□□-□

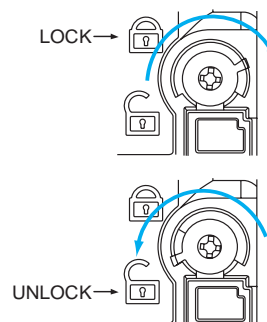

D4SL-N□□□□-□4

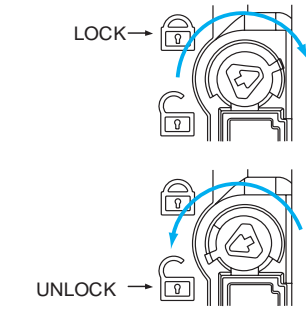

Back

D4SL-N□□□□-□

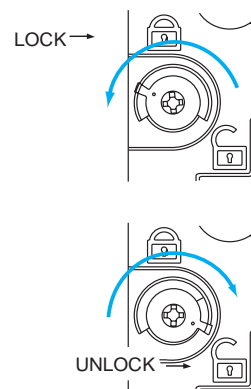

D4SL-N□□□□-□4

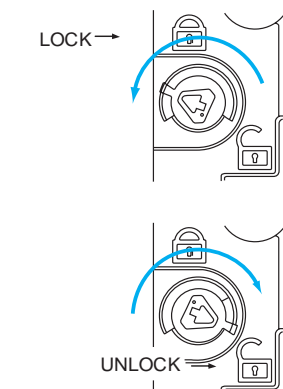

- After setting the release key to UNLOCK to, for example, perform maintenance, be sure to return it to LOCK setting before resuming operation.
- The release key is set in the unlock position at the factory for the D4SL-N□□□□A and to the lock position for the D4SL-N□□□□G.
- In the unlock position, even when the door of large machines or stamping machines is closed during preliminary adjustment, the door will remain unlocked and the machines will not be activated.
- Do not use the release key to start or stop machines.
- The auxiliary lock must be released only by authorized personnel.
- Do not impose a force exceeding 0.2 N•m on the release key screws. The release key may be damaged and may not operate properly.
- To prevent the release key from being used by unauthorized personnel, set it to LOCK and seal it with sealing wax.

Mounting Covers

- Confirm that the seal rubber has no defects before use. If the seal rubber is displaced or raised, or has foreign particles adhered to it, the sealing capability of the seal rubber will be adversely affected.

Hinged Door

- If the Switch is mounted too close to the hinge, the force imposed on the lock will be much larger than for locations far from the hinge and the lock may be damaged. Mount the Switch close to the handle.

Mounting

Appropriate Tightening Torque

Loose screws may result in malfunction. Tighten the screws to the specified torques.

Cover mounting screw	0.4 to 0.5 N•m
Operation Key mounting screw	2.4 to 2.8 N•m (D4SL-NK□ and -NK□S)
	0.75 to 1.15 N•m (D4SL-NK□G)
Switch mounting screw	0.75 to 1.15 N•m
Connector	1.8 to 2.2 N•m (except 1/2-14NPT)
	1.4 to 1.8 N•m (1/2-14NPT)
Terminal screw * Terminal block type only	0.5 to 0.6 N•m (D4SL-N□□□□□-□□)

Switch and Operation Key Mounting

- Mount the Switch and Operation Key securely to the applicable tightening torque with M4 screws. Always use washers.
- The switch can be fastened more firmly by a stud (4 mm dia., 1.5 mm max height) inserted from back side at the hole of the switch.

Switch mounting

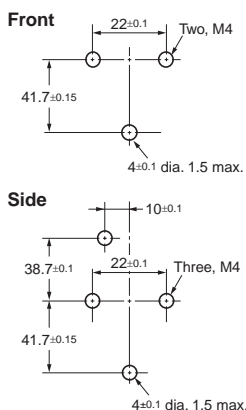

Operation Key mounting

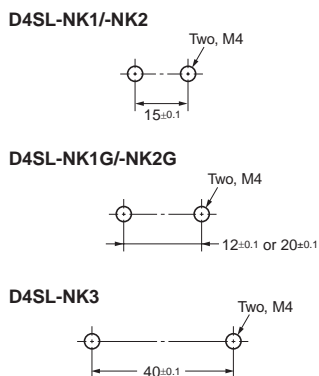

- Do not impose excessive force on the key top while the operation key is inserted into the switch body or drop the switch with the operation key inserted to avoid the deformation of the key or the breakage of the switch body.
- Do not use the operation key other than dedicated OMRON's (D4SL-NK□). Otherwise switch may be damaged.
- Do not use the operation key D4SL-K□. A lock will not be closed and a machine will not be activated.
- Be sure that the operation key can be inserted properly to key hole with a tolerance of ±0.8 mm.
- Insert the operation key into the key hole according to the specified "operation key insertion radius in horizontal direction".
- When mounting at the side of switch body, mount the switch with 3 points including the head.
- Attach cap heads to any operation key holes that are not being used.

Securing the Door

When the door is closed (with the Operation Key inserted), the Operation Key may exceed the set zone because of, for example, the door's own weight, machine vibration, or the door cushion rubber.

Secure the door with a stopper (hook) so that the Operation Key remains within the set zone.

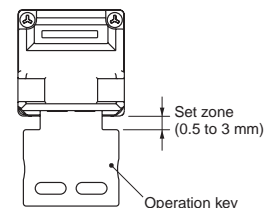

Spacer

Do not remove a spacer. Rotate the spacer in accordance with the Switch mounting direction. Use of the Switch without spacer will reduce the lock strength.

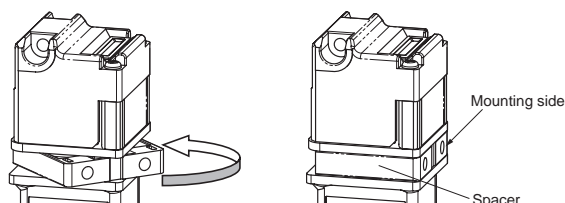

Wiring

Circuit Connection Example

- Direct opening contacts used as safety-circuit inputs are indicated with the ⊕ mark.
- DC solenoids have polarity. (E1: +, E2: -) Confirm terminal polarity before wiring.
- The current of the 24 VDC solenoid is different from when it is first turned ON as to when it is in operation. To take into account possible voltage drops, it is important to apply a rated operation voltage.
- To enable the 24 VDC solenoid, it is necessary to select the appropriate power supply capacity.
- The ON and OFF contact operation will not engage simultaneously. Be sure to confirm operation under actual operating conditions.
- If a lock is required for safety, design the system so that the closing of the NC contacts on both the door open/closed detection switch and the lock monitor switch is detected.

(D4SL-N□N□□□-D□)

Contacts 12 and 41 and contacts 22 and 51 are internally connected.

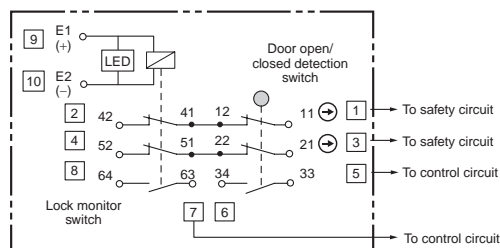

(D4SL-N□SF□□-□)

There is no internal connection, so connect contacts 22 and 42 or 21 and 42 externally.

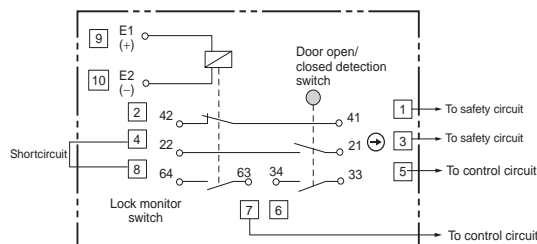

D4SL-N / D4SL-NSK10-LK□

Wiring Precautions for D4SL-N□□□□-□□

- Do not wire the Switch while power is being supplied. Doing so may result in electric shock.
- Do not let particles, such as small pieces of lead wire, enter the switch body when wiring.
- Do not directly wire the stranded wire to the terminal block.
- When connecting to the terminals via insulating tube and bar terminals, arrange the bar terminals so that they do not rise up onto the case or the cover.
- Applicable lead wire size: AWG22 to AWG18 (0.3 to 0.75 mm²).
- Use lead wires of an appropriate length. Not doing so may result in excess length causing the cover to rise and not fit properly.
- Remove the terminal block board out of the unit to perform wiring. Be sure to insert the connector properly.
- Do not pull on the lead wires with excessive force. Doing so may disconnect them.

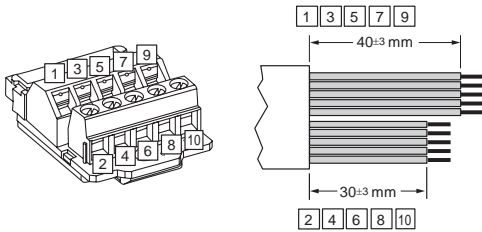

Recommended Crimp Terminals

Manufacturer	Model	Applicable wire lead
PHOENIX CONTACT	AI0.34-8 TQ	AWG22
	AI0.5-8 WH	AWG20
	AI0.75-8 GY	AWG18

L1: 14 mm max.

L2: 8 mm max.



Wiring Precautions for D4SL-N□□□□-□□□

- Do not wire the Switch while power is being supplied. Doing so may result in electric shock.
- Do not let particles, such as small pieces of lead wire, enter the switch body when wiring.
- Applicable lead wire size: AWG24 to AWG22 (0.2 to 0.3 mm²). Do not apply a current of 2 A or more when using AWG24.
- Use lead wires of an appropriate length. Not doing so may result in excess length causing the cover to rise and not fit properly.

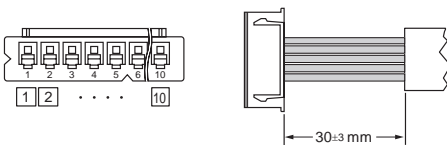

- Do not pull on the lead wires with excessive force. Doing so may disconnect them.
- Do not forcibly insert the wired socket at the cable side into the connector or D4SL-N's conduit opening. Doing so may cause cable break.
Be sure to insert the cable into the connector or D4SL's conduit opening before performing wiring to the socket, or insert the cable into the connector or conduit opening from the opposite side of the socket.

Applicable socket for cable side

Manufacturer	Name	Model
J.S.T. Mfg Co.	Housing	XHP-10
	Contact (applicable wire lead: AWG24 to AWG22)	SXH-001T-P0.6

Processing the Conduit Opening

- Connect a recommended connector to the opening of the conduit and tighten the connector to the proper torque. The case may be damaged if excessive tightening torque is applied.
- Use the cable with the connector-specified outside diameter.
- For the 1/2-14NPT conduit, mount a provided conversion adapter to use the connector above.

Recommended Connectors

- Use a connector with a screw section not exceeding 9 mm. Otherwise the screws will protrude into the case interior. The connectors given in the following table have connectors with screw sections not exceeding 9 mm. Use the following connectors to ensure conformance to IP67.

Size	Manufacturer	Model	Applicable cable diameter	Remarks
G1/2	LAPP	ST-PF1/2 5380-1002	6.0 to 12.0 mm	
	Ace Service Co.	LS-2G	6.0 to 11.0 mm	Short type
M20	LAPP	ST-M20×1.5 5311-1020	7.0 to 13.0 mm	
1/2-14NPT	LAPP	ST-NPT1/2 5301-6030	6.0 to 12.0 mm	

- Use LAPP connectors together with Seal Packing (JPK-16 for G1/2, or GPM20 for M20), and tighten to the applicable torque. Seal Packing is sold separately.
- LAPP is a German manufacturer.
- Ace Service Co. is a Japanese manufacturer.

D4SL-NSK10-LK□

- Use this product for a lightweight door (20 kg max). Otherwise the product may be damaged.
- This product is for D4SL-N Guard Lock Safety-door Switch only. This product cannot be used with any other manufacturer's door switches.
- Use the Slide Handle in the direction A or B in the following figure.

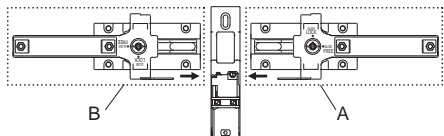

- Loose screws may result in malfunction. Use washers and tighten the screws to the specified torques. Mount the Slide Base at four points with screws. Adding adhesive is recommended for preventing the screws from loosening. Also, when mounting the Product to a door for disable-prevention purposes, purchase and use tamper-resistant screws.

Appropriate Tightening Torque

Slide Key mounting screw (M6)	6.0 to 7.0 N•m
Operation key special mounting screw (screws supplied)	2.4 to 2.8 N•m
Switch special mounting screw (screws supplied)	0.75 to 1.15 N•m
Inner Lever	9 to 10 N•m

Technical Specifications

Ambient operating temperature	-10 to 55°C (with no icing)
Ambient operating humidity	95% max.
Mechanical durability	20,000 operations min.

- Do not store the Switch where corrosive gases (e.g., H₂S, SO₂, NH₃, HNO₃ or Cl₂) or dust is present, or in locations subject to high temperature or humidity.
- Perform maintenance inspections periodically.
- When the lockout key is attached to your wrist, be careful that the strap does not get stuck in equipment.

Nomenclature

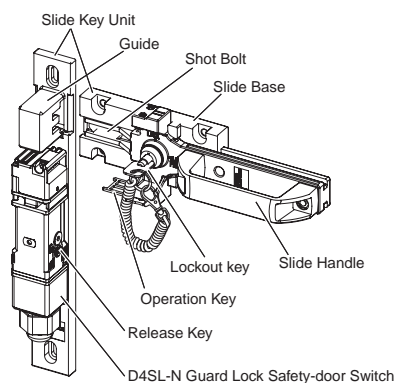

Differences between Lockout Key and Trapped Key (Reference)

	Lockout key	Trapped key (Refer to information on the D4JL-□□□A-□7-□□)
Closing the door	The door cannot be closed unless the lockout key is inserted in the slide and turned.	The door cannot be closed unless the trapped key is inserted in the Door Switch and turned.
Opening the door	The door can be opened by supplying power to the Door Switch solenoid without operating the lockout switch.	The door can never be opened without both supplying power to the Door Switch solenoid and operating the trapped key.

- When mounting the operation key, line up the inside edges of the long operation key holes with the outer edges of the slide handle as in the following figure to ensure easy position adjustment.

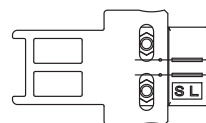

- Use the supplied special screws to mount the operation key and D4SL-N Guard Lock Safety-door Switch.
- To tighten the screws, use the tip of a flat-head screwdriver on the screw heads as shown in the following figure.



Note: The special screws are designed so that they cannot be turned counter-clockwise using a flat-head screwdriver.

- The special screws cannot be removed once they are tightened.

Mounting of inner lever
Mounting method

1) Detaching of mounting screw

Remove the handle mounting screw with TORX screwdriver (T30).

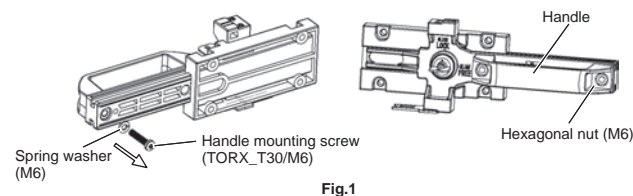

2) Mounting of inner lever

Tighten A portion of the inner lever to a suitable torque with wrench (width across flat: 10mm).

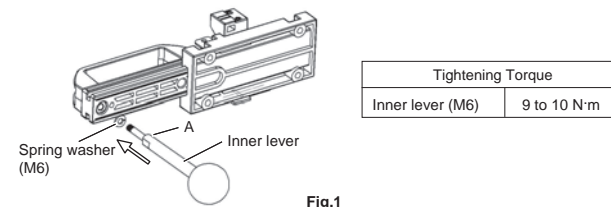

- This product is for Omron, the D4SL-NSK10 and the D4GL-SK10 only. This product cannot be used with any other products.
- Do not operate the handle with the handle mounting screw removed. Doing so may result in malfunction.
- Be careful not to lose the spring washer and hexagonal nut when remove the handle mounting screw. (Fig.1)
- Loose inner lever may result in malfunction. Use washers and tighten the inner lever to the specified torque. (Fig.2)

READ AND UNDERSTAND THIS CATALOG

Please read and understand this catalog before purchasing the products. Please consult your OMRON representative if you have any questions or comments.

Warranty and Limitations of Liability

WARRANTY

OMRON's exclusive warranty is that the products are free from defects in materials and workmanship for a period of one year (or other period if specified) from date of sale by OMRON.

OMRON MAKES NO WARRANTY OR REPRESENTATION, EXPRESS OR IMPLIED, REGARDING NON-INFRINGEMENT, MERCHANTABILITY, OR FITNESS FOR PARTICULAR PURPOSE OF THE PRODUCTS. ANY BUYER OR USER ACKNOWLEDGES THAT THE BUYER OR USER ALONE HAS DETERMINED THAT THE PRODUCTS WILL SUITABLY MEET THE REQUIREMENTS OF THEIR INTENDED USE. OMRON DISCLAIMS ALL OTHER WARRANTIES, EXPRESS OR IMPLIED.

LIMITATIONS OF LIABILITY

OMRON SHALL NOT BE RESPONSIBLE FOR SPECIAL, INDIRECT, OR CONSEQUENTIAL DAMAGES, LOSS OF PROFITS OR COMMERCIAL LOSS IN ANY WAY CONNECTED WITH THE PRODUCTS, WHETHER SUCH CLAIM IS BASED ON CONTRACT, WARRANTY, NEGLIGENCE, OR STRICT LIABILITY.

In no event shall responsibility of OMRON for any act exceed the individual price of the product on which liability is asserted.

IN NO EVENT SHALL OMRON BE RESPONSIBLE FOR WARRANTY, REPAIR, OR OTHER CLAIMS REGARDING THE PRODUCTS UNLESS OMRON'S ANALYSIS CONFIRMS THAT THE PRODUCTS WERE PROPERLY HANDLED, STORED, INSTALLED, AND MAINTAINED AND NOT SUBJECT TO CONTAMINATION, ABUSE, MISUSE, OR INAPPROPRIATE MODIFICATION OR REPAIR.

Application Considerations

SUITABILITY FOR USE

OMRON shall not be responsible for conformity with any standards, codes, or regulations that apply to the combination of products in the customer's application or use of the product.

At the customer's request, OMRON will provide applicable third party certification documents identifying ratings and limitations of use that apply to the products. This information by itself is not sufficient for a complete determination of the suitability of the products in combination with the end product, machine, system, or other application or use.

The following are some examples of applications for which particular attention must be given. This is not intended to be an exhaustive list of all possible uses of the products, nor is it intended to imply that the uses listed may be suitable for the products:

- Outdoor use, uses involving potential chemical contamination or electrical interference, or conditions or uses not described in this document.
- Nuclear energy control systems, combustion systems, railroad systems, aviation systems, medical equipment, amusement machines, vehicles, safety equipment, and installations subject to separate industry or government regulations.
- Systems, machines, and equipment that could present a risk to life or property.

Please know and observe all prohibitions of use applicable to the products.

NEVER USE THE PRODUCTS FOR AN APPLICATION INVOLVING SERIOUS RISK TO LIFE OR PROPERTY WITHOUT ENSURING THAT THE SYSTEM AS A WHOLE HAS BEEN DESIGNED TO ADDRESS THE RISKS, AND THAT THE OMRON PRODUCT IS PROPERLY RATED AND INSTALLED FOR THE INTENDED USE WITHIN THE OVERALL EQUIPMENT OR SYSTEM.

Disclaimers

CHANGE IN SPECIFICATIONS

Product specifications and accessories may be changed at any time based on improvements and other reasons.

It is our practice to change model numbers when published ratings or features are changed, or when significant construction changes are made. However, some specifications of the product may be changed without any notice. When in doubt, special model numbers may be assigned to fix or establish key specifications for your application on your request. Please consult with your OMRON representative at any time to confirm actual specifications of purchased products.

DIMENSIONS AND WEIGHTS

Dimensions and weights are nominal and are not to be used for manufacturing purposes, even when tolerances are shown.

ERRORS AND OMISSIONS

The information in this document has been carefully checked and is believed to be accurate; however, no responsibility is assumed for clerical, typographical, or proofreading errors, or omissions.

PERFORMANCE DATA

Performance data given in this catalog is provided as a guide for the user in determining suitability and does not constitute a warranty. It may represent the result of OMRON's test conditions, and the users must correlate it to actual application requirements. Actual performance is subject to the OMRON Warranty and Limitations of Liability.

PROGRAMMABLE PRODUCTS

OMRON shall not be responsible for the user's programming of a programmable product, or any consequence thereof.

Copyright and Copy Permission

COPYRIGHT AND COPY PERMISSION

This document shall not be copied for sales or promotions without permission.

This document is protected by copyright and is intended solely for use in conjunction with the product. Please notify us before copying or reproducing this document in any manner, for any other purpose. If copying or transmitting this document to another, please copy or transmit it in its entirety.

OMRON Corporation Industrial Automation Company

Tokyo, JAPAN

Contact: www.ia.omron.com

Regional Headquarters

OMRON EUROPE B.V.

Wegalaan 67-69-2132 JD Hoofddorp

The Netherlands

Tel: (31)2356-81-300/Fax: (31)2356-81-388

OMRON SCIENTIFIC TECHNOLOGIES INC.

6550 Dumbarton Circle,

Fremont, CA 94555-3605 U.S.A.

Tel: (1) 510-608-3400/Fax: (1) 510-744-1442

OMRON ASIA PACIFIC PTE. LTD.

No. 438A Alexandra Road # 05-05/08 (Lobby 2),

Alexandra Technopark,

Singapore 119967

Tel: (65) 6835-3011/Fax: (65) 6835-2711

OMRON (CHINA) CO., LTD.

Room 2211, Bank of China Tower,

200 Yin Cheng Zhong Road,

PuDong New Area, Shanghai, 200120, China

Tel: (86) 21-5037-2222/Fax: (86) 21-5037-2200

Authorized Distributor:

© OMRON Corporation 2012. All Rights Reserved.
In the interest of product improvement,
specifications are subject to change without notice.

CSM_5_1_0413

Cat. No. **C146-E1-01**

0512 (0412)